

SWIFT - ASSEMBLY MANUAL

PACKING LIST

Frame	pcs
Inner desk frame	1
Outer desk frame	1
Cable clamp	2
Hole cap	4
Column	2
End pipe	2
Feet	2
Control box / Hand control	pcs
Control box	1
Hand control	1
AC cable	1
Screw and wrench	pcs
Screw for motor house, M6x12mm	8
Screw for feet, M6x16mm	8
Screw for hand control, Ø4x22mm	2
Screw for tabletop, Ø5x20mm	20
Hexagonal wrench, 5mm	1

Tightening torque

Screw for motor house	Maximum 6Nm
Screw for feet and tabletop	Maximum 10Nm
Screw for hand control	< 6Nm

Make sure all screws are tightened, also after a period of use!

Reset the desk before use

Press both up and down buttons at the same time for 3 seconds. Continue pressing the buttons until both columns are in lowest position. When finish reset, the control box makes a sound and the buttons can be released. Now the system is operational.

WARNING

Carefully arrange all the cables not to be damaged by tabletop screws.

ergonice[®]
ERGONOMIC WORKSPACES

Step 1



Step 2



Step 3

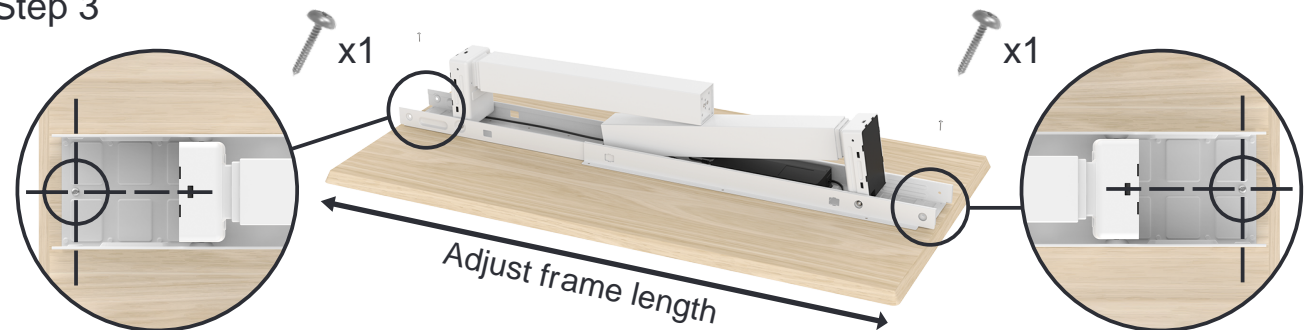

Step 4

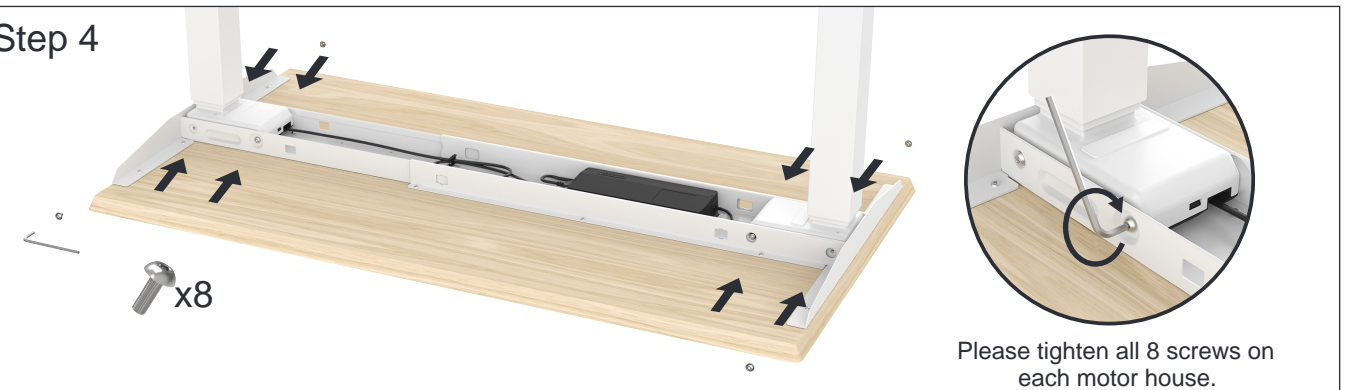

Please tighten all 8 screws on each motor house.

Step 5

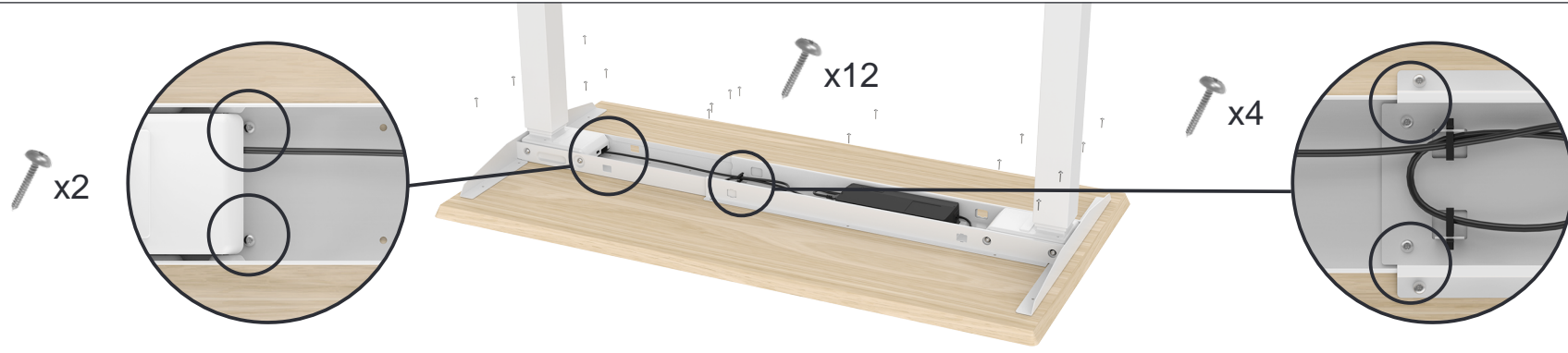

Step 6

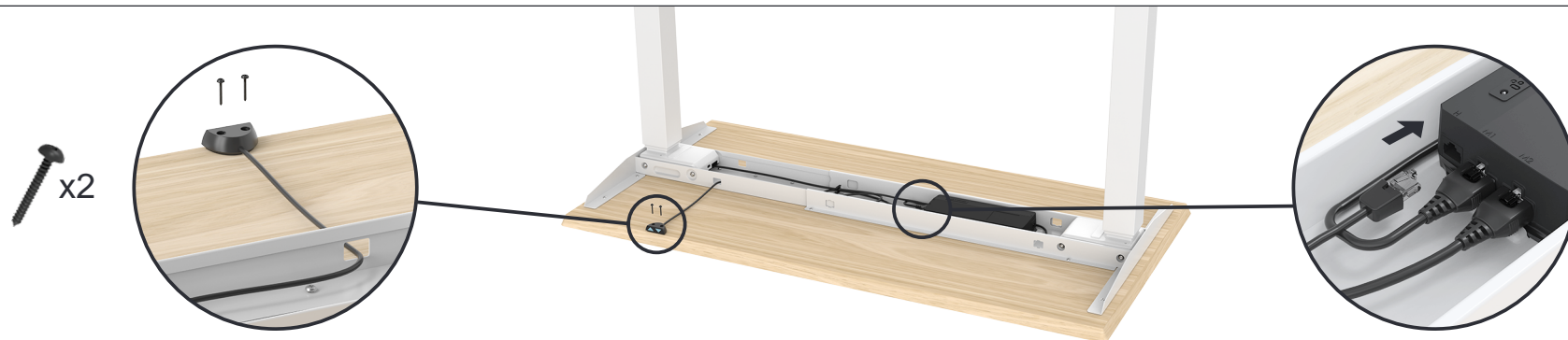

Step 7

